

Free Standing Post For Fold Up Rails

INSTALLATION INSTRUCTIONS

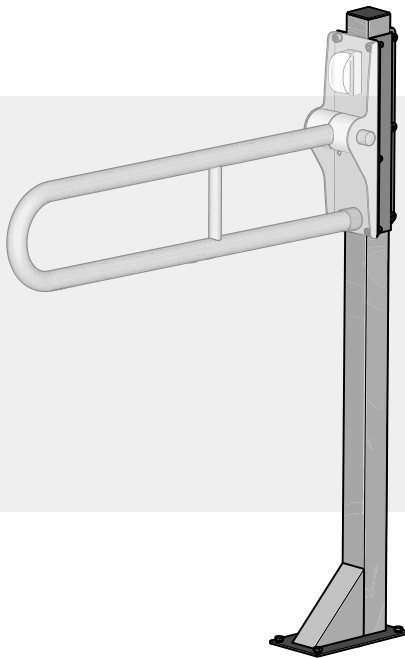

Rail not included



Read all instructions before installation and leave this document with the end user for future reference as it contains important warranty information

Important Information

Dimensions

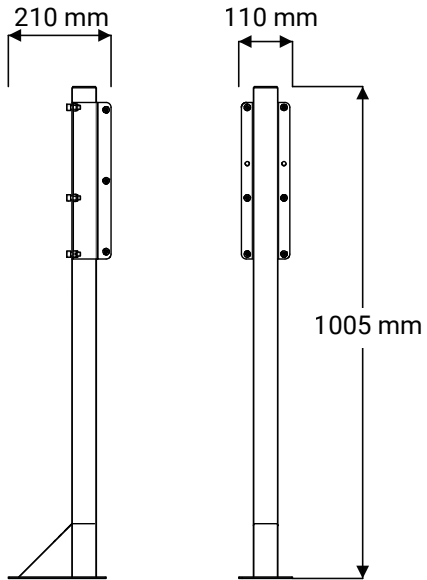

Parts Supplied

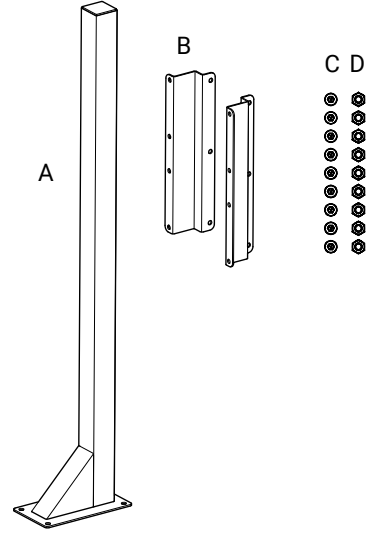

| Parts | QTY |
|------------------------|-----|
| A Post | 1 |
| B Post Clamp Bracket | 2 |
| C M8 Bolt | 9 |
| D M8 Nut | 9 |

Installation must be carried out in accordance with these instructions, and must be conducted by a qualified and competent installer.

Before you start

Please remove all protective covering and examine carefully. Check that all items are present before discarding all packaging. Please notify the retailer immediately of any damage or faults. The manufacturer cannot be held responsible for any installation costs that may arise from damaged or faulty products being installed and not in accordance with these instructions. The guarantee does NOT cover impact related damage, see warranty details. Please dispose all packaging in accordance with local recycling authorities.

Safety

- Handle with care.
- Have the correct tools available.
- Must be fitted to a solid floor.
- When drilling walls or floors, check first for hidden pipes and cables.
- Use safety eye wear when drilling.
- Keep small parts and packaging away from children.

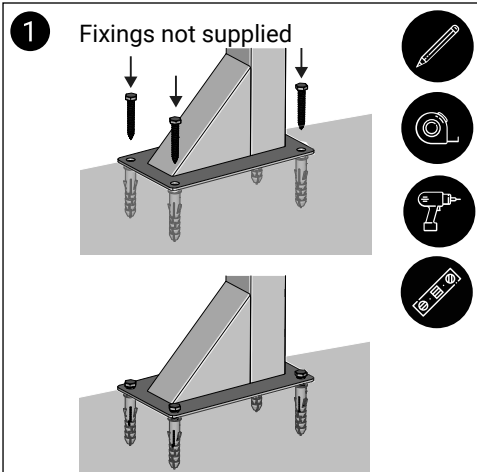

Pre-assemble and check all parts are present. Determine the positioning of the post and fold up rail. Mark the floor position using the pre-drilled holes in the floor plate. Drill suitable sized holes and insert the floor anchors. Mount the post to the floor using suitable floor mounting screws or bolts.

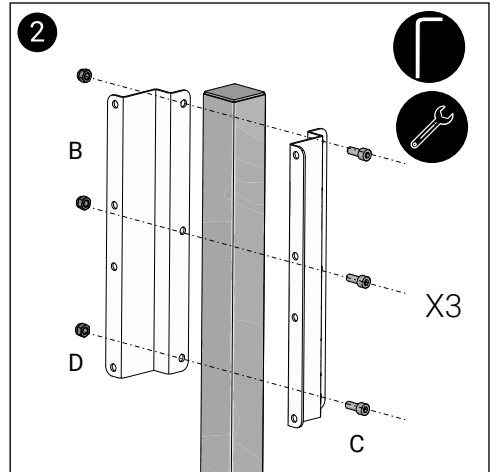

Assemble the post clamping brackets together using 3 x M8 bolts and nuts using 5mm Allen key.

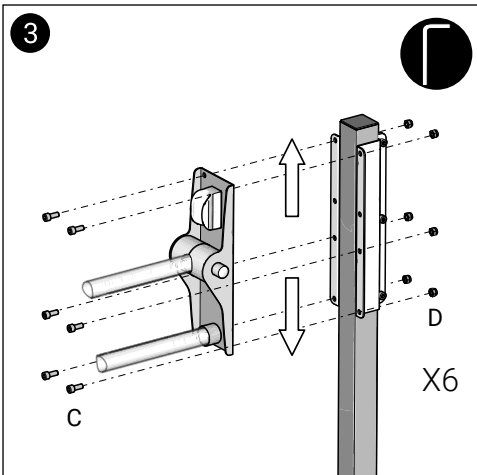

Attach the fold up rail bracket onto the post clamping brackets using 6 x M8 bolts and nuts. Select a suitable height before clamping together tightly using 5mm Allen key. Do not over tighten fixings.

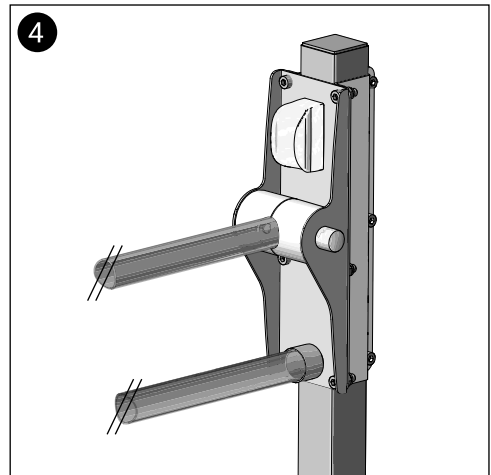

Test the fold up rail action and ensure the post and frame is stable and does not move. Further height adjustment maybe required by adjusting the bracket.

Do not use abrasive cleaning chemicals or scouring cloths as this will affect the surface finish.

Orders & Quotes

01905 823 299
orders@akw-ltd.co.uk

General Enquiries

01905 823 298
sales@akw-ltd.co.uk

Technical Enquiries

01905 560 219
technicalenquiries@akw-ltd.co.uk

Kitchen Enquiries

01905 823 262
kitchens@akw-ltd.co.uk

Fax

01905 823 297

AKW

Pointon Way, Hampton Lovett
Droitwich Spa, WR9 0LR

www.akw-ltd.co.uk
orders.akw-ltd.co.uk



Guarantee

The guarantee only applies to manufacturing or material defects. This is conditional on the one-time correct installation of the product and does not apply to breakages, inappropriate use or accidental damage. This guarantee does not cover damage caused by the lack of maintenance including the build up of dirt, grime or damage caused by extreme temperature changes. This does not cover damage resulting from inappropriate cleaning or staining. This guarantee excludes general wear and tear through usage and does not apply to surface finishes or defects that result from unintended use or modifications.

What to do if something goes wrong?

In the event that you should encounter a problem with this product, please contact your local installer and if this does not resolve the issue, then contact AKW technical team who will provide further advice and, if necessary, arrange for a maintenance engineer to visit and report any issues. See the T&Cs on our website or in our catalogue for further information. None of the foregoing affects your statutory rights.